

# DESVM6004

## Stanchion kit

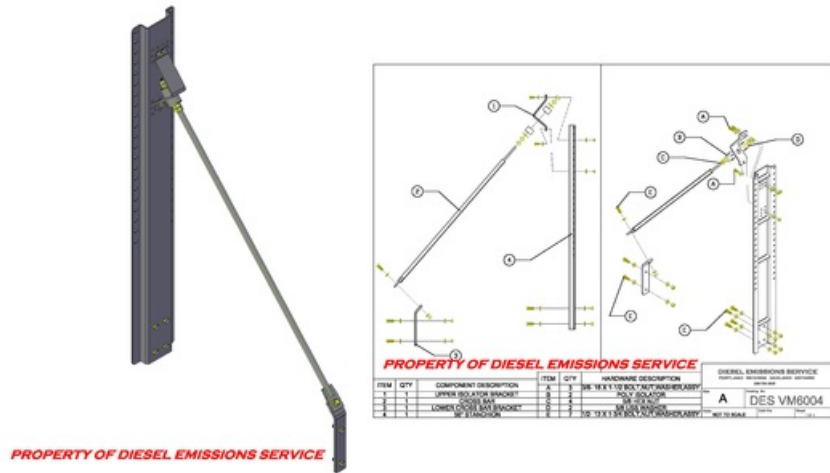

\*Due to continuous improvements to our products, actual items ordered and received may differ slightly from images shown.

## Features:

- Threaded cross bar support utilizes rubber isolators mounting kit brackets are designed to mount "passive" DPF systems (NOT EXCEEDING 125 lbs.) vertically utilizing rubber isolation.
- Vertical stanchion bracket has welded channel reinforcement to resist harmonic vibrations.
- Constructed and welded using mild steel.
- All parts are powder coated black.
- All hardware (hex bolts, flat washers, nylock nuts) are yellow zinc chromate, grade 8 (included).

## Installation:

1. Brackets must be assembled as shown and hardware torqued to \*\*listed standards, FAILURE TO DO SO MAY CAUSE DAMAGE TO THE "DPF" SYSTEM OR INJURY TO PERSONS.
2. Position cross bar support bracket on back of the stanchion as shown. Drill location holes as needed while maintaining alignment of isolators and hardware to reduce wear and ensure long life of isolation components.
3. Do not tighten isolation hardware to the listed torque specifications! Reasonable care should be taken when tightening, to avoid excessive compression of the isolator. FAILURE TO DO SO MAY CAUSE DAMAGE TO THE "DPF" SYSTEM OR INJURY TO PERSONS.
4. \*\*TORQUE SPECIFICATIONS: 3/8-16 GRADE 8 (40-50 ft lbs.) 7/16-14 GRADE 8 (60-75 ft lbs.) 1/2-13 GRADE 8 (90-110 ft lbs.) (1/2-13 90-110 ft lbs.)