

# DES7242

DPF Enclosure 42" (inside width) "FL/KW" style

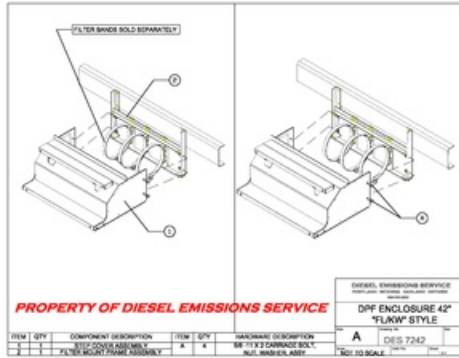
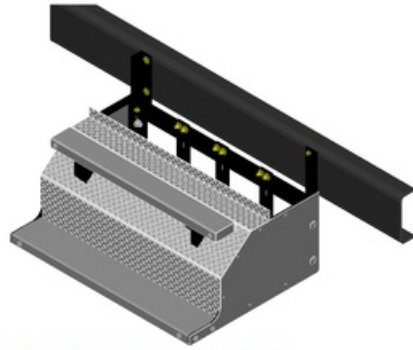

\*Due to continuous improvements to our products, actual items ordered and received may differ slightly from images shown.

## Features:

- DES7242 is designed as an enclosure to mount your DPF in and give the appearance and styling of factory "OEM" tool boxes found on various Freightliner and Kenworth model trucks.
- DES7242 is designed to mount filters with a maximum length of 42". These filters are mounted to the chassis of the DPF enclosure with bands purchased separately.
- The DES7242 chassis is constructed and welded using 1/4" and 3/8" mild steel.
- Steps and side panels are 5000 series marine grade aluminum. Cover is polished 3000 series aluminum. This entire assembly can be removed for access to the filter by simply removing (4) bolts.
- Chassis hardware (hex bolts, flat washers, nylock nuts) are yellow zinc chromate, grade 8, Cover hardware is grade 5 zinc plated (included).

## Installation:

1. Remove existing tool box and choose the proper location for the new DPF enclosure. Mark and drill new mounting holes as needed.
2. All components must be assembled as shown and hardware torqued to \*\*listed standards, Tighten band hardware as necessary to prevent crushing of the filter outer can. FAILURE TO DO SO MAY CAUSE DAMAGE TO THE "DPF" SYSTEM.
3. IMPORTANT Filter can be mounted opposite of normal exhaust flow direction depending on existing exhaust configuration needs.
4. \*\*TORQUE SPECIFICATIONS: 3/8-16 GRADE 8 (40-50 ft lbs.) 7/16-14 GRADE 8 (60-75 ft lbs.) 1/2-13 GRADE 8 (90-110 ft lbs.) 5/8-11 GRADE 5 (110-150 ft lbs.)