

DESM9022/M9023/M9024/M9025

DONALDSON 9.5"-10.5"

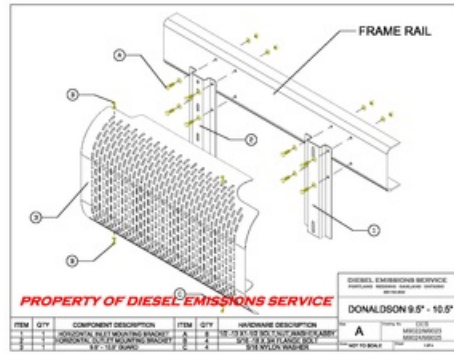
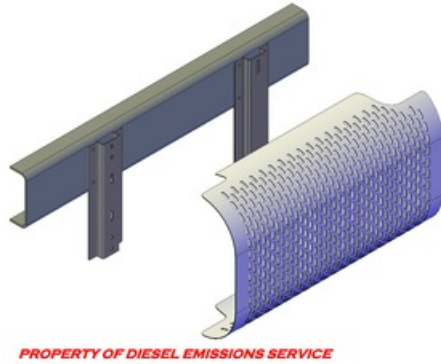

*Due to continuous improvements to our products, actual items ordered and received may differ slightly from images shown.

Features:

- DES M9022/M9023/M9024/M9025 mounting kits are designed to mount the Donaldson 9.5" and 10.5" Dual DPF system.
- Constructed using mild steel.
- All parts are powder coated in black.
- Guard made from Marine Grade Aluminum with a bright finish.
- All hardware (hex bolts, flat washers, nylock nuts) are yellow zinc chromate, grade 8 (included).

Installation:

1. Brackets must be assembled as shown and hardware torqued to **listed standards, FAILURE TO DO SO MAY CAUSE DAMAGE TO THE DPF SYSTEM OR INJURY TO PERSONS.
2. Components should be oriented as shown before before tightening all fasteners.
3. Position the adjustable filter mount to ensure adequate ground clearance between filter and roadway.
4. Maintain adequate clearance between drive train components.
5. ** TORQUE SPECIFICATIONS: 3/16-16 GRADE 8 (40-50 ft lbs.) 7/16-14 GRADE 8 (60-75 ft lbs.) 1/2-13 GRADE 8 (90- 110 ft lbs.)